

**PRELIMINARY TECHNICAL INFORMATION**

**HIGHLIGHTS**

- Wide range.
- Reliability.
- Short delivery time
- Modular system.
- Cooling system included.
- Current, voltage and temperature sensors.
- IGBT drivers included.
- Ready to use.



Foto no contractual / Non-contractual photo

**ABOUT MT SERIES**

RECTIFICADORES GUASCH S.A. offers the most modifiable way for designing power stages AC-AC or DC-AC by connecting rectifier block, DC-link block and IGBT power stack. This way, the customer (and not the builder) decides which the block that limits the power of the entire system. The customer can obtain in a short delivery time a wide range of power assemblies in a compact size.

Each block is designed for obtaining the maximum efficiency by itself in the minimum dimensions. MT series is suitable to realize converters, choppers, half, full or three phases bridge inverters for motor control, welding, renewable energies, UPS...

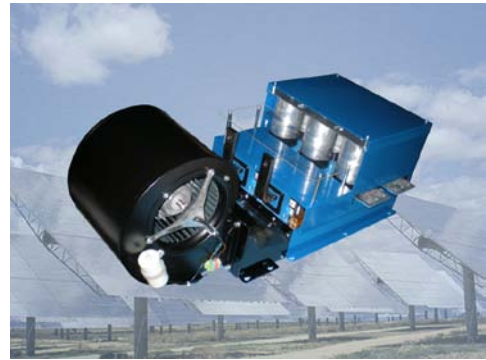
**BRIEFING**

Topology	B6I + capacitor bank
Market	industrial
Cooling system	centrifugal fan
Driver system	SCiCoreLink67
Parameters monitored	DC voltage, Output current (each phase) temperature on heatsink, internal module NTC
Max Voltage applied to DClink	800 V
Output current per phase	fsw=1kHz, TJ<125°C Tamb=40°C fo=50Hz P.F.=0,85 m=1 VDClink=600V 942 A

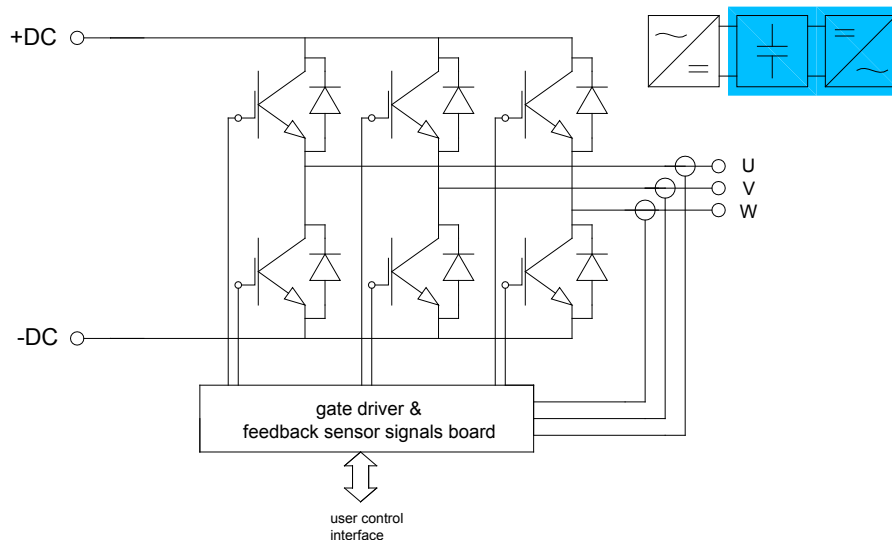

090629Rev.:0

**RECTIFICADORES GUASCH, S.A.**

Ciutat de Granada, 80  
08005 BARCELONA  
SPAIN

Se reserva el derecho de cambiar los límites, las condiciones de prueba y dimensiones indicadas en esta hoja sin previo aviso.  
Reserves the right to change limits, test conditions and dimensions given in this data sheet at any time without previous notice.

Tel.: +34 93 309 88 91  
Fax.: +34 93 300 18 41  
e-mail: info@e-guasch.com  
www.e-guasch.com

## POWER STACK GENERAL CHARACTERISTICS

Description	symbol	notes/test conditions	Min	Typ	Max	Units
Voltage applied to DClink	$V_{DClink}$	<b>note 1</b>		600	800	$V_{DC}$
Output current per phase	$I_{U,V,W}$	fsw=1kHz, T <sub>J</sub> <125°C Tamb=40°C fo=50Hz P.F.=0,85 m=1 VDClink=600V			942	$A_{RMS}$
IGBT maximum junction temperature	$T_{Jmax}$				150	°C
IGBT temp. under switching conditions	$T_{J(sw)}$		-40		125	°C
Storage temperature	$T_{stg}$		-40		85	°C
Operating temperature	$T_{op}$		-25		85	°C
Power-to-control isolation voltage	$V_{ISOp-c}$	50 Hz @1min/ <b>note 2</b>	3			$kV_{AC}$
Module isolation voltage	$V_{ISOmod}$	50 HZ @1min/ <b>note 3</b>	2,5			kV
Mounting Torque DC terminals		M8	8		10	N·m
Weight (aprox)					38.5	kg

## COOLING SYSTEM CHARACTERISTICS

Description	symbol	notes/test conditions	Typical	Units
Type		centrifugal fan		
Fan system supply voltage	$V_{FAN}$		230	$V_{RMS}$
Fan system consumption	$I_{FAN}$	50Hz/60Hz	1,11/1,36	A

## IGBT MODULE ELECTRICAL CHARACTERISTICS

Description	symbol	notes/test conditions	Min	Typ	Max	Units
Collector-Emitter Voltage	$V_{CES}$	T <sub>J</sub> =25°C			1200	V
DC Collector current	$I_{Cnom}$	T <sub>C</sub> =80°C, T <sub>J</sub> =150°C			1400	A
Repetitive peak collector current	$I_{CRM}$	t <sub>p</sub> =1ms			2800	A
Power dissipation (per module)	$P_{DISS}$	T <sub>C</sub> =25°C, T <sub>J</sub> =150°C			7650	W
Collector-emitter saturation voltage	$V_{CEsat}$	Ic=1400 A, T <sub>J</sub> =125°C		2,05		V

**note 1:** This voltage is limited by IGBT module. Restriction by DC Link capacitors voltage must be considered.

**note 2:** This isolation voltage is referred to the minimum isolation voltage between any control/feedback signal (PWM, reset fault, feedback sensor signals and supply of boards) and any power voltage (DC input, AC output).

**note 3:** This is an inner property of the IGBT module. It refers to the isolation between the internal chip and the external case.

### RECTIFICADORES GUASCH, S.A.

Ciutat de Granada, 80  
08005 BARCELONA  
SPAIN

Se reserva el derecho de cambiar los límites, las condiciones de prueba y dimensiones indicadas en esta hoja sin previo aviso.  
Reserves the right to change limits, test conditions and dimensions given in this data sheet at any time without previous notice.

Tel.: +34 93 309 88 91  
Fax.: +34 93 300 18 41  
e-mail: info@e-guasch.com  
www.e-guasch.com

## CAPACITOR BANK CHARACTERISTICS

Description	symbol	Typical	Units
Single capacitor	C	MKP type 420uF -15%..0% 1100V	
Total equivalent capacitance	$C_{equiv}$	3780	$\mu$ F
max capacitor bank DC voltage	$V_{DClink}$	1100	<b>note 4</b> V

## ENVIRONMENTAL SPECIFICATIONS

Description	
Protection grade (EN-60529 / CEI529 / UNE-20324)	IP-00
Humidity max.	50% RH @ 35°C / 90% RH @ 20°C
Pollution degree	III

## MOUNTING CONSIDERATIONS

It's necessary a minimum distance of 100 mm with regard to the envelope. The free air circulation should be guaranteed. Avoiding the heat sources of nearby to assembly.

In the real applications it is important to consider a safety margin with regarding the working current, we recommend a margin of the 20%.

For critical cases (24 hours work, repetitive overloads...), margins of the 30% to 50% are used.

090629Rev.:0

**note 4:** This voltage is limited by DC Link capacitors. Restriction by IGBT maximum voltage must be considered.

### RECTIFICADORES GUASCH, S.A.

Ciutat de Granada, 80  
08005 BARCELONA  
SPAIN

Se reserva el derecho de cambiar los límites, las condiciones de prueba y dimensiones indicadas en esta hoja sin previo aviso.  
Reserves the right to change limits, test conditions and dimensions given in this data sheet at any time without previous notice.

Tel.: +34 93 309 88 91  
Fax.: +34 93 300 18 41  
e-mail: [info@e-guasch.com](mailto:info@e-guasch.com)  
[www.e-guasch.com](http://www.e-guasch.com)

**MECHANICAL DIMENSIONS**

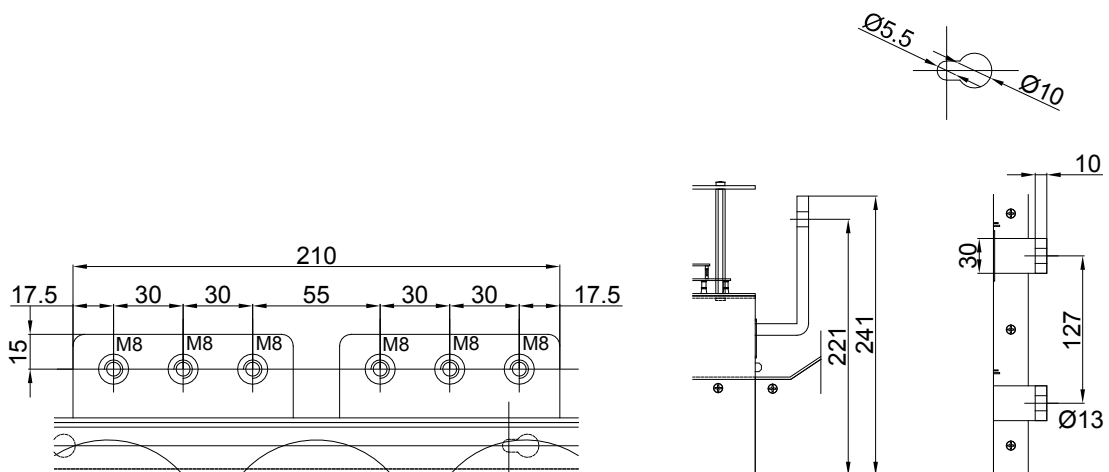
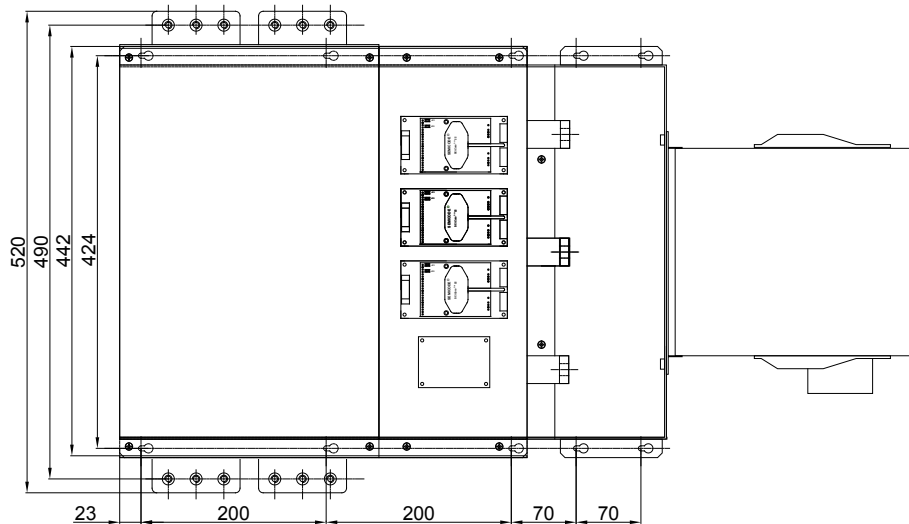
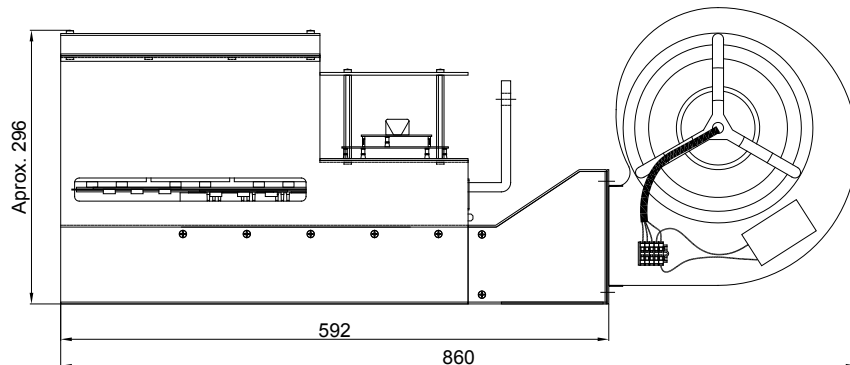

All dimensions in millimeters

090629 Rev.:0

**POWER AND CONTROL CONNECTION**

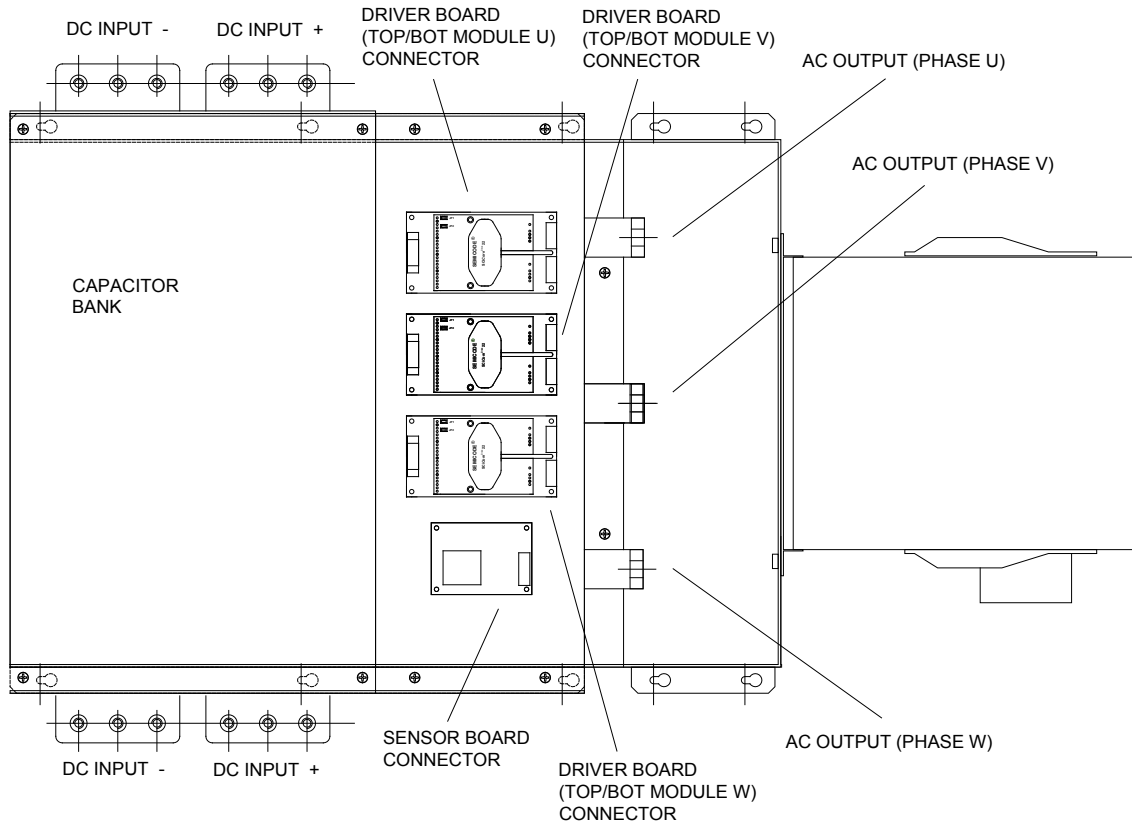

090629Rev.:0

**RECTIFICADORES GUASCH, S.A.**

Ciutat de Granada, 80  
08005 BARCELONA  
SPAIN

Se reserva el derecho de cambiar los límites, las condiciones de prueba y dimensiones indicadas en esta hoja sin previo aviso.  
Reserves the right to change limits, test conditions and dimensions given in this data sheet at any time without previous notice.

Tel.: +34 93 309 88 91  
Fax.: +34 93 300 18 41  
e-mail: info@e-guasch.com  
www.e-guasch.com

**GATE DRIVER BOARD ELECTRICAL CHARACTERISTICS**

Description	symbol	notes/test conditions	Min	Typ	Max	Units
Supply voltage	$V_{CC}$			15		V
Current consumption	$I_{CC}$	$f_{sw} = 10\text{kHz}; Q_{G/pulse} = 6\mu\text{C}$		370		mA
PWM & reset High state Input voltage	$V_{IN\_H}$	JP1 to 5V connected	3,5		5	V
PWM & reset Low state Input voltage	$V_{IN\_L}$		0		1,5	V
PWM & reset High state Input voltage	$V_{IN\_H}$	JP1 to 15V connected	11		15	V
PWM & reset Low state Input voltage	$V_{IN\_L}$		0		4	V
Fault High state Output Voltage	$V_{FAULT\_H}$	working in logic lev; JP1 to 15V			15	V
Fault High state Output Voltage	$V_{FAULT\_H}$	working in logic lev; JP1 to 5V			5	V
Fault (working as open collector) current	$I_{FAULT}$	working as open collector			20	mA

**GATE DRIVER BOARD PINOUT**

CON 1	designation	function
1	PWM <sub>TOP</sub>	Input logic signal for switching TOP IGBT
2	GND	Ground terminal for supply and logic signals
3	GND	Ground terminal for supply and logic signals
4	RESET	reset input signal (low state)
5	GND	Ground terminal for supply and logic signals
6	VCC	+15VDC for supply voltage
7	FAULT	fault output signal
8	VCC	+15VDC for supply voltage
9	VCC	+15VDC for supply voltage
10	PWM <sub>BOT</sub>	Input logic signal for switching BOT IGBT

JUMPERS	
JP1	right connected: 15V logic level left connected: 5V logic level
JP2	right connected: half bridge mode left connected: direct mode

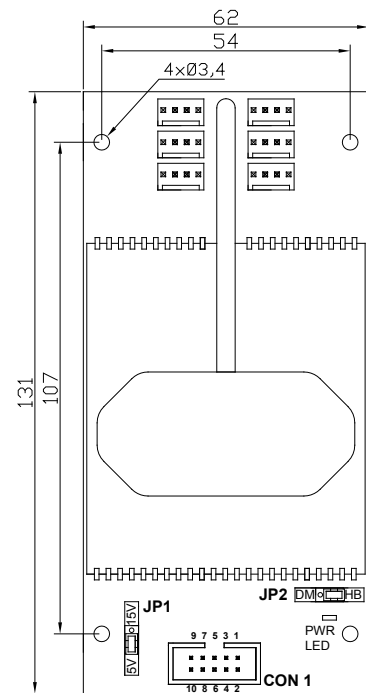

All dimensions in mm.

**DEFAULT VALUES**

- half bridge mode (direct mode optional)
- 4µs dead time between channels generated
- Gate resistor depending of the IGBT module used
- 0-5V input PWM and reset logic levels (0-15V optional)
- 0-5V logic fault output (0-15V or low level-open collector fault output optional)

**RECTIFICADORES GUASCH, S.A.**

Ciutat de Granada, 80  
08005 BARCELONA  
SPAIN

Se reserva el derecho de cambiar los límites, las condiciones de prueba y dimensiones indicadas en esta hoja sin previo aviso.  
Reserves the right to change limits, test conditions and dimensions given in this data sheet at any time without previous notice.

Tel.: +34 93 309 88 91  
Fax.: +34 93 300 18 41  
e-mail: info@e-guasch.com  
www.e-guasch.com

090629 Rev.:0

**SENSOR BOARD ELECTRICAL CHARACTERISTICS**

Description	symbol	notes/test conditions	Min	Typ	Max	Units
Supply voltage	V <sub>CC</sub>			±15		V
Feedback signal of heatsink temp.	V <sub>T</sub>	relative error <2,5%	0		12	V
Heatsink temp. measurable range			0		120	°C
Feedback signal of output current	V <sub>CX</sub>	relative error <3%	0		10	V
Current measurable range			-2400		2400	A
Feedback signal of VDC-link voltage	V <sub>U</sub>	relative error <2,8%	0		15	V
DC-link measurable voltage range			0		1500	V <sub>DC</sub>
Thermostat		Normally connected		90		°C
NTC rated resistance	R <sub>NTC 25</sub>	internal module NTC TC=25°C		5		kΩ
NTC B value	B <sub>25/50</sub>	<b>note 1</b>		3375		K

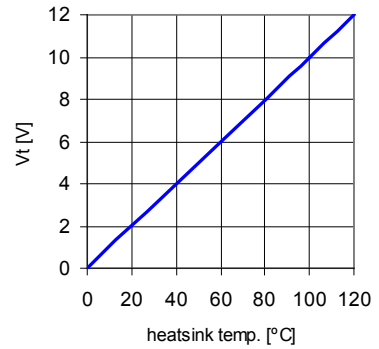
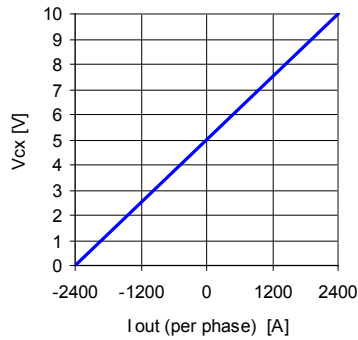
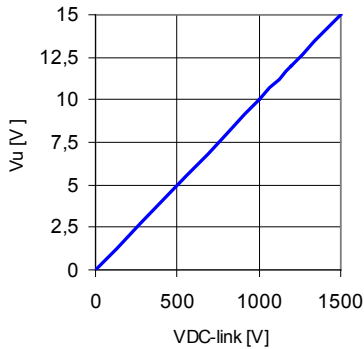

**SENSOR BOARD PINOUT**

CON 2	designation	function
1	+15Vcc	+15VDC for supply voltage
2	NTCA1	NTC terminal 1 of IGBT module A
3	NTCB2	NTC terminal 2 of IGBT module B
4	NTCB1	NTC terminal 1 of IGBT module B
5	NTCC1	NTC terminal 1 of IGBT module C
6	NTCA2	NTC terminal 2 of IGBT module A
7	NTCC2	NTC terminal 2 of IGBT module C
8	TH <sub>2</sub>	Thermostat terminal 2
9	V <sub>T</sub>	Output voltage representation of heatsink temperature
10	TH <sub>1</sub>	Thermostat terminal 1
11	V <sub>C V</sub>	Output voltage representation of phase V output current
12	V <sub>U</sub>	Output voltage representation of VDC-link voltage
13	V <sub>C W</sub>	Output voltage representation of phase W output current
14	V <sub>C U</sub>	Output voltage representation of phase U output current
15	-15Vcc	-15VDC for supply voltage

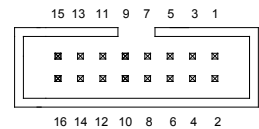

note 1:

$$R_T = R_{25} \cdot e^{B \left( \frac{1}{T[K]} - \frac{1}{298,15K} \right)}$$

090629Rev.:0

**RECTIFICADORES GUASCH, S.A.**

Ciutat de Granada, 80  
08005 BARCELONA  
SPAIN

Se reserva el derecho de cambiar los límites, las condiciones de prueba y dimensiones indicadas en esta hoja sin previo aviso.  
Reserves the right to change limits, test conditions and dimensions given in this data sheet at any time without previous notice.

Tel.: +34 93 309 88 91  
Fax.: +34 93 300 18 41  
e-mail: info@e-guasch.com  
www.e-guasch.com

**PERFORMANCE CURVES**

Stack working as an inverter

**T<sub>J\_IGBT</sub> vs I<sub>OUT</sub> (per phase, AC output)**

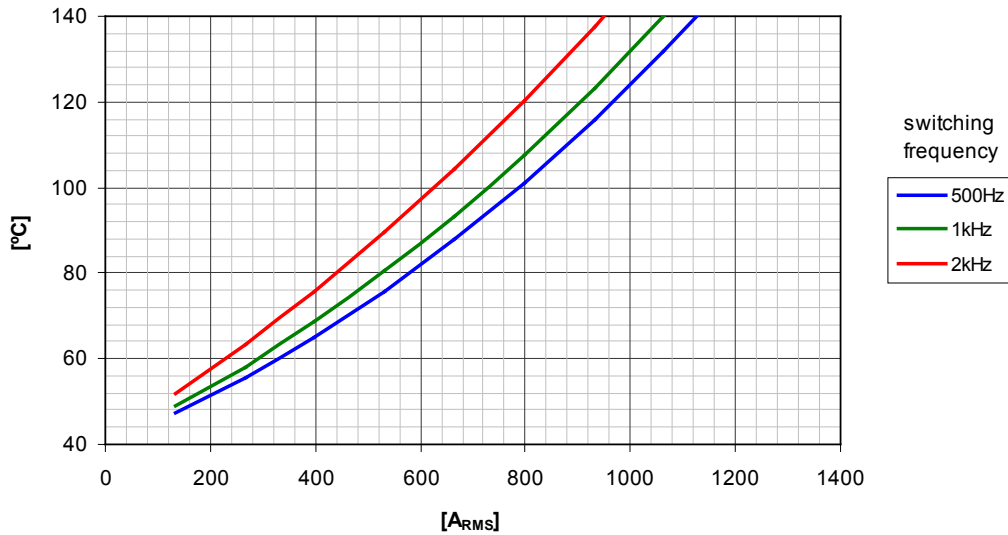

Condition	Symbol	Value	Units
Ambient temperature	T <sub>A</sub>	40	°C
DCLink Voltage	V <sub>DCLink</sub>	600	V
Load Power Factor	PF	0,85	
Modulation index	m	1	
Output frequency	f <sub>OUT</sub>	50	Hz

090629 Rev.:0





## ANOTACIONES EN LA HOJA DE ESPECIFICACIONES:

RECTIFICADORES GUASCH, S.A. utiliza la siguiente anotación para identificar el estado del producto, en el lado izquierdo de la primera página:

**PRELIMINARY TECHNICAL INFORMATION:** El producto se encuentra en proceso de diseño y desarrollo. La información presenta los datos del producto pero algunas características pueden cambiar.

**ADVANCED TECHNICAL INFORMATION:** El producto se encuentra totalmente diseñado y las características se refieren a la fabricación en serie.

Sin anotación: Los parámetros del producto están fijados y se suministra de acuerdo con las especificaciones publicadas.

Los datos indicados en esta publicación corresponden a especificaciones de producto, queda excluida cualquier garantía expresa o implícita sobre sus propiedades o su aplicación, así como cualquier responsabilidad sobre daños directos o indirectos producidos por los materiales o resultantes de su aplicación. La empresa se reserva el derecho de realizar cambios en las especificaciones de los productos sin previo aviso. La información respecto a métodos de uso y aplicaciones se indica sólo como guía y no constituye garantía alguna de funcionamiento satisfactorio en un determinado equipo o aplicación. Es responsabilidad del usuario determinar la idoneidad del producto para su aplicación utilizando la información disponible y asegurarse de que la misma está actualizada.

Cualquier nombre de producto o marca usada en esta publicación corresponde a marcas depositadas, marcas registradas o nombres protegidos por sus respectivos propietarios.



## DATASHEET ANNOTATIONS:

RECTIFICADORES GUASCH, S.A. annotate datasheets in the left corner of the front page, to indicate product status:

**PRELIMINARY TECHNICAL INFORMATION:** The product is in design and development. The datasheet represents the product as it is understood but details may change.

**ADVANCED TECHNICAL INFORMATION:** The product design is complete and final characterisation for volume production is well in hand.

No Annotation: The product parameters are fixed and the product is available to datasheet specification.

The technical data are to specify components, not to guarantee their properties. No warranty or guarantee expressed or implied is made regarding delivery or performance. The Company reserves the right to alter without prior notice the specification of any product. Information concerning possible methods of use is provided as a guide only and does not constitute any guarantee that such methods of use will be satisfactory in a specific piece of equipment. It is the user's responsibility to fully determine the performance and suitability of any equipment using such information and to ensure that any publication or data used is up to date.

All brand names and product names used in this publication are trademarks, registered trademarks or trade names of their respective owners.



## DATASHEET ANNOTATIONS:

RECTIFICADORES GUASCH, S.A. Indiqué dans la notice technique a la part inferieur à gauche le suivant pour vous informer de la situation du produits

**PRELIMINARY TECHNICAL INFORMATION:** Le produit est dans la conception et le développement. La notice technique représente le produit comme il a été conçu mais les détails peuvent changer.

**ADVANCED TECHNICAL INFORMATION:** La conception de produit est fini et la notice technique est comme il a été conçu pour la fabrication.

Sans annotation: La notice technique indique que le produit est selon la même

Les données indiquées dans la notice technique sont conformément aux spécifications des composants, sont exclues toutes autres conditions ou garanties exprimées ou implicites concernant la qualité et le bon fonctionnement des matériels, ainsi que toute responsabilité pour les dommages causés directement ou indirectement par les matériels ou résultant de leur utilisation. Nous nous réservons la possibilité de changement sans notification. L'information à propos des méthodes possibles d'usage est fournie comme un guide conformément aux spécifications et instructions et ne constitue pas garantie que telles méthodes d'usage sera satisfaisant dans un morceau spécifique d'équipement. C'est la responsabilité de l'Acheteur déterminer l'exécution et l'aptitude du produit et s'assurer qu'il a la dernière actualisation de la notice technique.

Des noms de marque et produit utilisés dans cette publication sont enregistrés et propriété de leurs propriétaires respectifs.

© RECTIFICADORES GUASCH, S.A.

DOCUMENTACION TECNICA, TECHNICAL DOCUMENTATION, DOCUMENTATION TECHNIQUE  
PRODUCIDO EN ESPAÑA, PRODUCED IN SPAIN, PRODUIT EN ESPAGNA  
PROHIBIDA SU VENTA, NOT FOR SALE, PAS A VENDRE

## Your Needs, Our Solutions

**RECTIFICADORES GUASCH, S.A.**

Ciutat de Granada, 80  
08005 BARCELONA  
SPAIN

Se reserva el derecho de cambiar los límites, las condiciones de prueba y dimensiones indicadas en esta hoja sin previo aviso.  
Reserves the right to change limits, test conditions and dimensions given in this data sheet at any time without previous notice.

Tel.: +34 93 309 88 91  
Fax.: +34 93 300 18 41  
e-mail: [info@e-guasch.com](mailto:info@e-guasch.com)  
[www.e-guasch.com](http://www.e-guasch.com)