

HIGHLIGHTS

- Wide range.
- Reliability.
- Short delivery time.
- Ultrafast fuses included.
- Thermostat, snubber and varistor included.
- Ready to use.
- Working voltage up to 400 V_{RMS}.
- Insulation 2500 V_{RMS}/1 min.

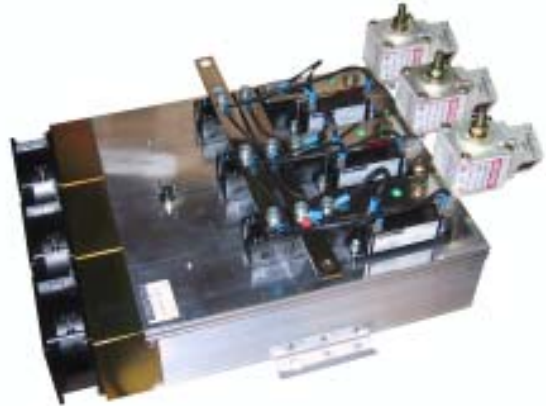

GENERAL SPECIFICATIONS

Nominal line to line input voltage (V _{RMS})	400 V _{AC} ±10%
Repetitive peak reverse voltage (V _{RRM})	1200 V _P
Maximum working current (I _{DC}) (1)	401 A _{DC} @ 35°C TA
Maximum nominal working current (I _{DC}) (2)	353 A _{DC} @ 35°C TA
Cooling	Forced air, 3 fans 80x80 @ 230V _{RMS}

(1): The maximum non continuous working current

(2): The maximum continuous working current without thermal protection activation

SEMICONDUCTOR SPECIFICATIONS

Peak non-repetitive surge current (I _{TSM})	6000 A @ T _P =10ms, T _J =45°C, (50Hz), sine
	5250 A @ T _P =10ms, T _J =125°C, (50Hz), sine
I ² t capacity for fusing	180 kA ² s @ T _P =10ms, T _J =45°C, (50Hz), sine
	137 kA ² s @ T _P =10ms, T _J =125°C, (50Hz), sine
Maximum rate of rise of on-state current (repetitive) (di _T /dt)	150 A/μs
Maximum rate of rise of on-state current (non-repetitive) (di _T /dt)	500 A/μs
Maximum peak on-state voltage (V _{TM})	1,25 V @ I _{TM} =300A
Critical rate of rise of off-state voltage (dv/dt)	Min. 1000 V/μs @ T _J =125°C, V _D =2/3 V _{RRM}
Gate trigger voltage (V _{GT})	max. 2,5 V @ T _J =25°C, V _D =6V
	max. 2,6 V @ T _J =-40°C, V _D =6V
Gate trigger current (I _{GT})	max. 150 mA @ T _J =25°C, V _D =6V
	max. 200 mA @ T _J =-40°C, V _D =6V
Latching current (I _L)	300 mA @ T _J =25°C, t _p =30μs; V _D =6V
Holding current (I _H)	200 mA @ T _J =25°C; V _D =6V

PROTECTION

dv/dt protection (RC)	RC network 0,068μF/150 Ohms
Peak voltage protection (VDR)	460 V _{RMS} varistor
Current protection (Semiconductor fuses) (1)	3 x 069UR1S0400B
Microswitch (fuse indicators)	3 x MS 3V1-5N
Thermal protection (Thermostats)	85°C NC

(1): Fuses only for shortcircuit protection. User provide external protection for continuous overloads and cable size.

RECTIFICADORES GUASCH, S.A.

Ciutat de Granada, 80
08005 BARCELONA
SPAIN

Se reserva el derecho de cambiar los límites, las condiciones de prueba y dimensiones indicadas en esta hoja sin previo aviso.
Reserves the right to change limits, test conditions and dimensions given in this data sheet at any time without previous notice.

Tel.: +34 93 309 88 91
Fax.: +34 93 300 18 41
e-mail: info@e-guasch.com
www.e-guasch.com

060427 Rev.:1

TERMINAL SPECIFICATIONS	
Input power terminals (AC terminals)	(M8) 11 to 13 Nm
Module power terminals	(M6) 4,5 to 5,5 Nm
Output power terminals (DC terminals)	2xØ8,5 (M8) 11 to 13 Nm (1)
SCR control terminals (G&K)	Fast-on 2,8/0,8 (2)
Thermal cut-off terminals	6,35 mm Fast-on

(1): The press should be performed with two keys, avoiding to transmit lateral efforts al terminal of connection, what would be able to produce the deterioration of the element semiconductor.

(2): Fast-on 2,8 mm connectors provided by user. In no case should be proceeded to the direct welding on these terminals.

ENVIRONMENT SPECIFICATIONS	
Protection grade (EN-60529 / CEI529 / UNE-20324)	IP-00
Humidity max.	50% RH @ 35°C / 90% RH @ 20°C
Pollution degree	III
Isolation	2500 V _{RMS} / 1 min

LOSSES	
Power dissipation of semiconductors at full charge	Aprox. 910 W
Maximum power dissipation of fuse at full charge	Aprox. 84 W
Maximum total power dissipation at full charge	Aprox. 993 W

MECHANICAL SPECIFICATIONS	
Mounting position	Any
Storage temperature	-25 to 80°C
Width	314 mm
Depth	378 mm
Height	189 mm
Aprox. Weight	13,10 Kg.

CIRCUIT SCHEMATICS

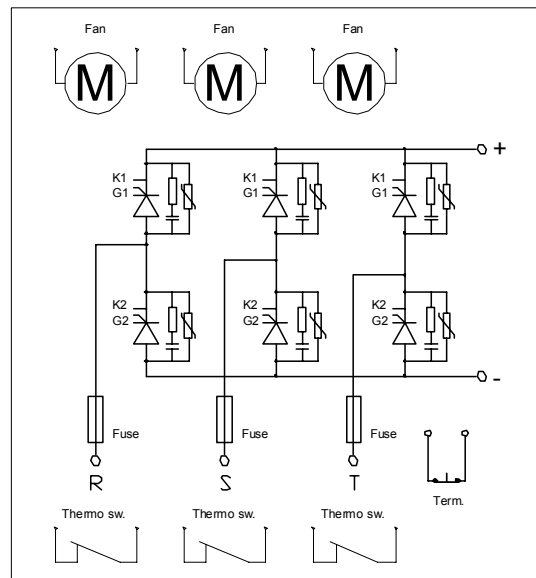
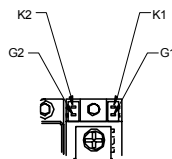
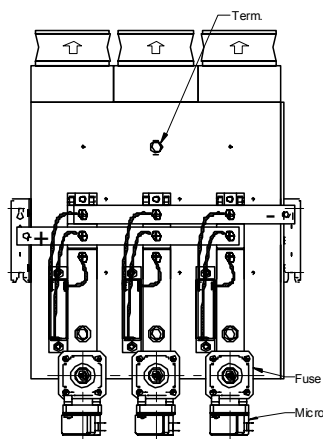

060427 Rev.:1

RECTIFICADORES GUASCH, S.A.

Ciutat de Granada, 80
08005 BARCELONA
SPAIN

Se reserva el derecho de cambiar los límites, las condiciones de prueba y dimensiones indicadas en esta hoja sin previo aviso.
Reserves the right to change limits, test conditions and dimensions given in this data sheet at any time without previous notice.

Tel.: +34 93 309 88 91
Fax.: +34 93 300 18 41
e-mail: info@e-guasch.com
www.e-guasch.com

DIMENSIONS

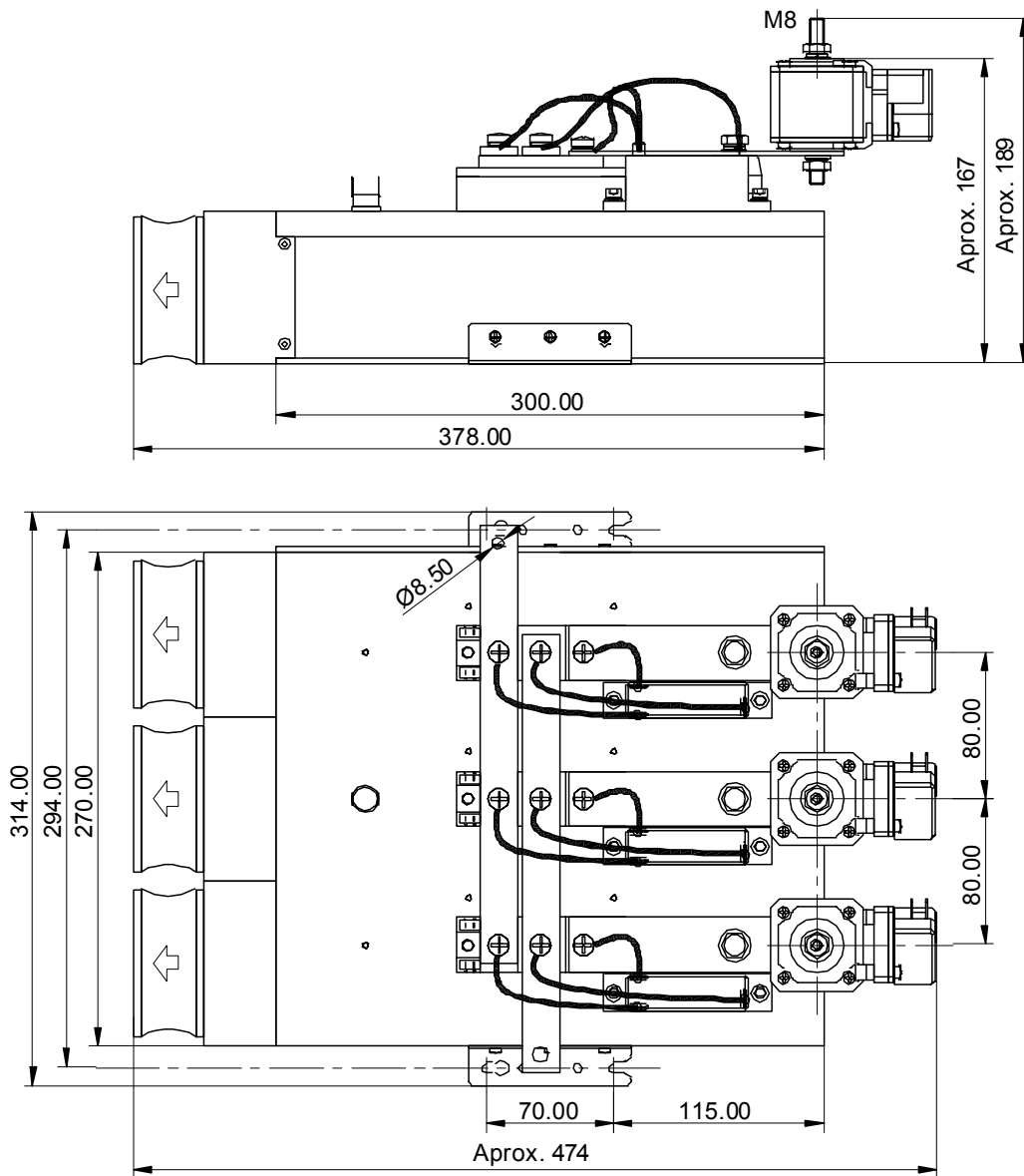

MOUNTING CONSIDERATIONS

It's necessary a minimum distance of 100 mm with regard to the envelope. The free air circulation should be guaranteed. Avoiding the heat sources of nearby to assembly.

In the real applications it is important to consider a safety margin with regarding the working current, we recommend a margin of the 20%.

For critical cases (24 hours work, repetitive overloads...), margins of the 30% to 50% are used.

060427 Rev.:1

RECTIFICADORES GUASCH, S.A.

Ciutat de Granada, 80
08005 BARCELONA
SPAIN

Se reserva el derecho de cambiar los límites, las condiciones de prueba y dimensiones indicadas en esta hoja sin previo aviso.
Reserves the right to change limits, test conditions and dimensions given in this data sheet at any time without previous notice.

Tel.: +34 93 309 88 91
Fax.: +34 93 300 18 41
e-mail: info@e-guasch.com
www.e-guasch.com

POWER AND CHARACTERISTIC CURVES

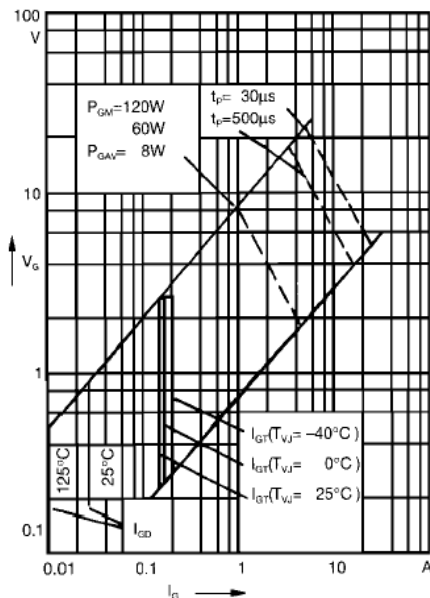
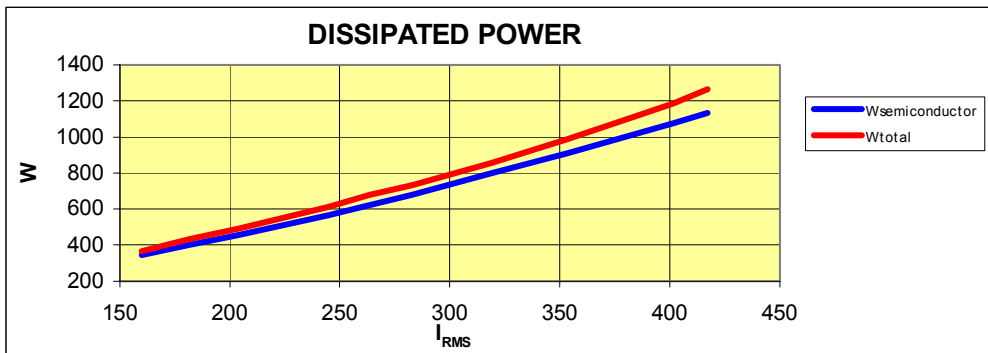
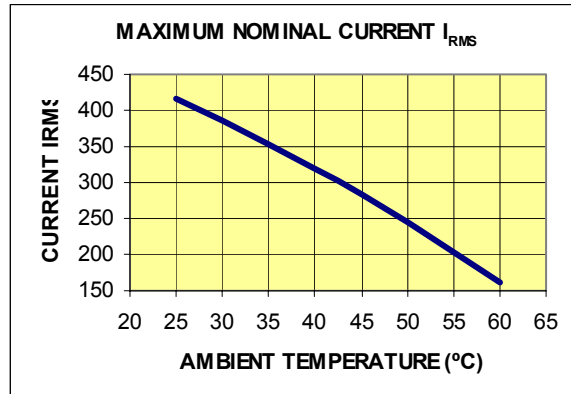

GATE TRIGGER LIMITS

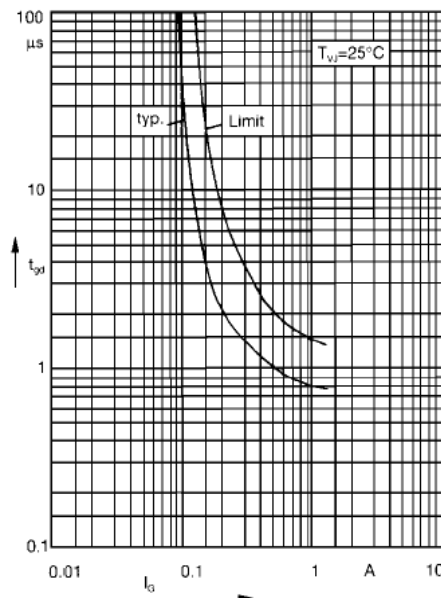

GATE POWER CURVES



ANOTACIONES EN EL «DATASHEET» :

RECTIFICADORES GUASCH, S.A. utiliza la siguiente anotación para identificar el estado del producto, en el lado izquierdo de la primera página:

PRELIMINARY TECHNICAL INFORMATION: El producto se encuentra en proceso de diseño y desarrollo. La información presenta los datos del producto pero algunas características pueden cambiar.

ADVANCED TECHNICAL INFORMATION: El producto se encuentra totalmente diseñado y las características se refieren a la fabricación en serie.

Sin anotación: Los parámetros del producto están fijados y se suministra de acuerdo con las especificaciones publicadas.

Los datos indicados en esta publicación corresponden a especificaciones de producto, queda excluida cualquier garantía expresa o implícita sobre sus propiedades o su aplicación, así como cualquier responsabilidad sobre daños directos o indirectos producidos por los materiales o resultantes de su aplicación. La empresa se reserva el derecho de realizar cambios en las especificaciones de los productos sin previo aviso. La información respecto a métodos de uso y aplicaciones se indica sólo como guía y no constituye garantía alguna de funcionamiento satisfactorio en un determinado equipo o aplicación. Es responsabilidad del usuario determinar la idoneidad del producto para su aplicación utilizando la información disponible y asegurarse de que la misma está actualizada.

Cualquier nombre de producto o marca usada en esta publicación corresponde a marcas depositadas, marcas registradas o nombres protegidos por sus respectivos propietarios.



DATASHEET ANNOTATIONS:

RECTIFICADORES GUASCH, S.A. annotate datasheets in the left corner of the front page, to indicate product status:

PRELIMINARY TECHNICAL INFORMATION: The product is in design and development. The datasheet represents the product as it is understood but details may change.

ADVANCED TECHNICAL INFORMATION: The product design is complete and final characterisation for volume production is well in hand.

No Annotation: The product parameters are fixed and the product is available to datasheet specification.

The technical data are to specify components, not to guarantee their properties. No warranty or guarantee expressed or implied is made regarding delivery or performance. The Company reserves the right to alter without prior notice the specification of any product. Information concerning possible methods of use is provided as a guide only and does not constitute any guarantee that such methods of use will be satisfactory in a specific piece of equipment. It is the user's responsibility to fully determine the performance and suitability of any equipment using such information and to ensure that any publication or data used is up to date.

All brand names and product names used in this publication are trademarks, registered trademarks or trade names of their respective owners.



DATASHEET ANNOTATIONS:

RECTIFICADORES GUASCH, S.A. Indiqué dans la notice technique à la part inférieur à gauche le suivant pour vous informer de la situation du produits

PRELIMINARY TECHNICAL INFORMATION: Le produit est dans la conception et le développement. La notice technique représente le produit comme il a été conçu mais les détails peuvent changer.

ADVANCED TECHNICAL INFORMATION: La conception de produit est fini et la notice technique est comme il a été conçu pour la fabrication.

Sans annotation: La notice technique indique que le produit est selon la même

Les données indiquées dans la notice technique sont conformément aux spécifications des composants, sont exclues toutes autres conditions ou garanties exprimées ou implicites concernant la qualité et le bon fonctionnement des matériels, ainsi que toute responsabilité pour les dommages causés directement ou indirectement par les matériels ou résultant de leur utilisation. Nous nous réservons la possibilité de changement sans notification. L'information à propos des méthodes possibles d'usage est fournie comme un guide conformément aux spécifications et instructions et ne constitue pas garantie que telles méthodes d'usage sera satisfaisant dans un morceau spécifique d'équipement. C'est la responsabilité de l'acheteur déterminer l'exécution et l'aptitude du produit et s'assurer qu'il a la dernière actualisation de la notice technique.

Des noms de marque et produit utilisés dans cette publication sont enregistrés et propriété de leurs propriétaires respectifs.

© RECTIFICADORES GUASCH, S.A.

DOCUMENTACION TECNICA, TECHNICAL DOCUMENTATION, DOCUMENTATION TECHNIQUE
PRODUCIDO EN ESPAÑA, PRODUCED IN SPAIN, PRODUIT EN ESPAGNA
PROHIBIDA SU VENTA, NOT FOR SALE, PAS A VENDRE

Your Needs, Our Solutions

RECTIFICADORES GUASCH, S.A.

Ciutat de Granada, 80
08005 BARCELONA
SPAIN

Se reserva el derecho de cambiar los límites, las condiciones de prueba y dimensiones indicadas en esta hoja sin previo aviso.
Reserves the right to change limits, test conditions and dimensions given in this data sheet at any time without previous notice.

Tel.: +34 93 309 88 91
Fax.: +34 93 300 18 41
e-mail: info@e-guasch.com
www.e-guasch.com