

PRELIMINARY TECHNICAL INFORMATION
GENERAL DESCRIPTION

Designed for the construction of static relays of great power to voltages up to $800V_{RMS}$, it produces the firing of 2 thyristors in antiparallel configuration (W1C) in the passage by zero of the network tension, which allows to obtain great advantages in the connection of loads (specially resistive).



Photo non-contractual

Using 2 or 3 modules it is possible to make three-phase applications with connection to 2 or 3 phases (W3.2C and W3C).

The specific characteristic of this product is its high inverse tension of tip ($2500V$), which allows to confront applications like the connection of condensers, for example, in equipment of regulation of reactive energy to tension of $690V_{RMS}$ network.

GENERAL DATA	
Maximum voltage	$800 V_{RMS} +10\%$ 42 a 63 Hz
Minimum recommended voltage	$100 V_{RMS}$ 42 a 63 Hz
Maximum peak voltage	2500 V.
Application circuit	W1C
Optional application circuits (more modules)	W3.2C; W3C

CONTROL	
Voltage	6 a $30V_{DC}$
Current	<25mA / modulo

LIGHT INDICATORS	
Control signal (on state)	Red LED

TRIGGER	
Typical turn-on voltage	12V

TERMINAL SPECIFICATIONS	
Control	Fast-on 2,8 x 0,5 mm.
Thyristors (gate and catode)	

ENVIRONMENT SPECIFICATIONS	
Protection grade	IP-00
Maximum humidity	50% Rh @ 35°C / 70% RH @ 20°C
Pollution grade	III
Isolation voltage (control-thyristors)	$2500 V_{RMS}$ / 1min

MECHANICAL PROPERTIES	
Module	92x40x30 mm.
Fixation	4 Holes $\varnothing 5,5$ (compatible to standard modules with 80 mm. interaxis)
Weight	135 grs.

080123 Rev.:0

DIMENSIONS

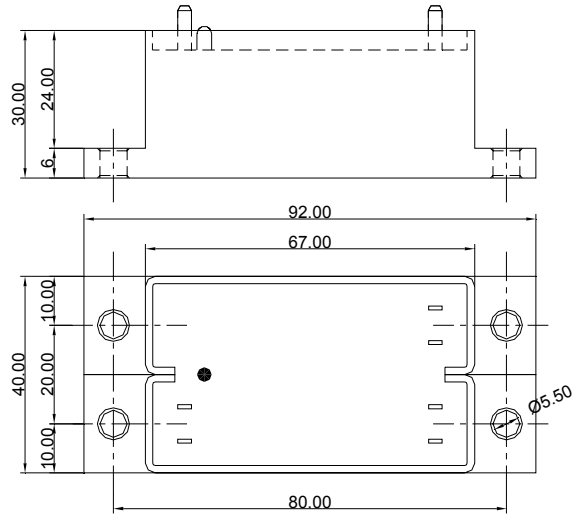

APPLICATION CIRCUIT

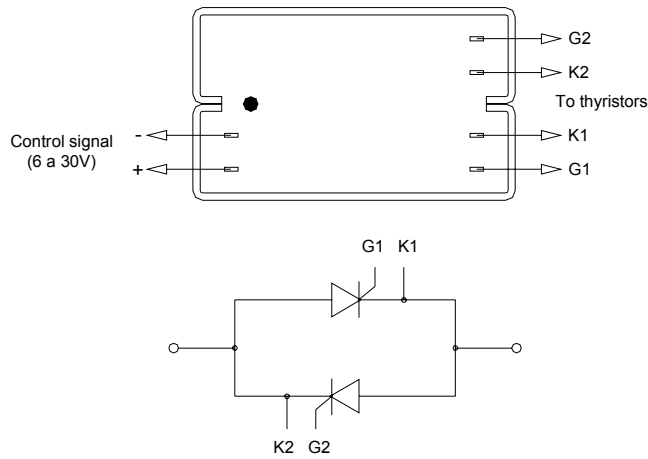

WAVE FORMS (STATIC RELAY - ELECTROMECHANICAL RELAY)

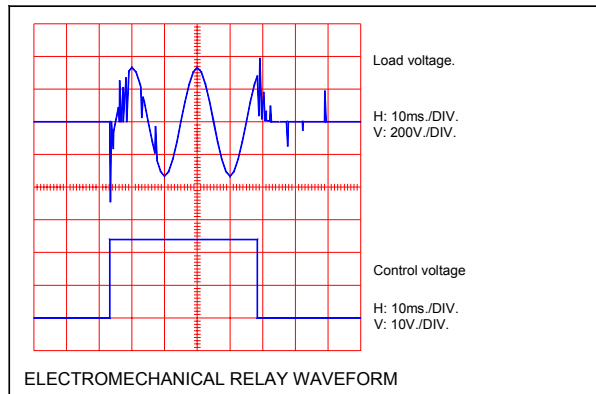
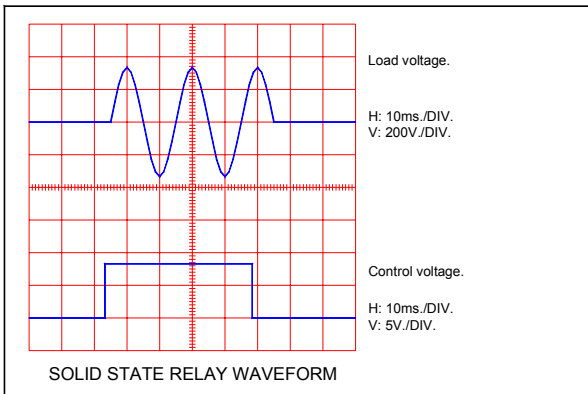

080123 Rev.:0

Cost Effective Products

SEMICODE ELECTRONICA

offers to the market a comprehensive range of products from recognized manufacturers at the best price/quality relationship, this products are provided with a basic reference code that allows maintaining the same product reference even if the original device manufacturer is replaced. SEMICODE product reference has to be considered as a generic brand.

Seeking the market needs and trends, we are constantly increasing the product portfolio with new products and suppliers, please ask for the updated information available to our local contacts.

SEMICODE products include semiconductors, passive components and accessories focused in power electronics market.

Datasheet Annotations:

SEMICODE ELECTRONICA annotate datasheets in the top left hard corner of the front page, to indicate product status. The annotations are as follows:

Tentative information: This is the most tentative form of information and represents a very preliminary specification. No actual design work on the product has been started.

Preliminary Information: The product is in design and development. The datasheet represents the product as it is understood but details may change.

Advance Information: The product design is complete and final characterisation for volume production is well in hand.

No Annotation: The product parameters are fixed and the product is available to datasheet specification.

NOTICE: The technical data are to specify components, not to guarantee their properties.No warranty or guarantee expressed or implied is made regarding delivery or performance. The Company reserves the right to alter without prior notice the specification of any product. Information concerning possible methods of use is provided as a guide only and does not constitute any guarantee that such methods of use will be satisfactory in a specific piece of equipment. It is the user's responsibility to fully determine the performance and suitability of any equipment using such information and to ensure that any publication or data used is up to date.

All brand names and product names used in this publication are trademarks, registered trademarks or trade names of their respective owners.

© SEMICODE ELECTRONICA 2008. TECHNICAL DOCUMENTATION – NOT FOR RESALE